

1 CNC-machined aluminium alloy finishing ring.

2 Pole cup CNC machined from a solid piece of ultra-low-carbon steel.

3 Oversized, high quality neodymium magnet. This "motor" guarantees a perfectly linear response and constant magnetic flux over the entire working range of the tweeter, assuring an extremely linear and neutral response both at low and high volumes. A careful study supported by FEM analysis allowed us to design the metal parts of the magnet to maximize the flow exactly around the voice coil, and make it linear throughout its entire excursion. Ventilation is ensured by a large opening on the bottom, protected by a filter with calibrated holes. This solution also reduces the peak impedance to the resonance frequency, making the tweeter easier to interface with any passive crossovers.

4 Magnet plate in ultra-low-carbon steel.

5 Body made of 7000 aluminum alloy and brass, manufactured entirely by numerical control (CNC). This makes the structure very rigid with practically zero tolerances, yielding consistency of performance and maximum linearity of reproduction, free from any vibration and/or resonance.

6 Residual resonances are neutralized by the under-dome, dB Cloth® damping material. This extends the frequency response to the lower limits and reduces harmonic distortion.

7 The large 50 mm diameter voice coil allows the use of much higher power for this kind of component. This perfect combination of power and lightness is necessary for a midrange that must reproduce frequencies in a linear and faithful way, even beyond the threshold of audibility. The voice coil uses an aluminum support to better disperse the temperature.

8 The carbon fiber reinforced, polymer matrix composite dome ensures extraordinary rigidity combined with a very low weight.

9 The faceplate.

10 Removable grill for dome protection.

Speaker Type: Component Midrange
 Nominal Diameter: 2"/50 mm
 Nominal Impedance (Znom): 4 Ohms
 Continuous Power Handling: 120 W
 Peak Power Handling: 240 W
 Rec. Amplifier Power: 50 - 160W (RMS)

PARAMETERS

Voice Coil Resistance (Re): 3.5 Ohms
 Voice Coil Diameter: 25 mm
 Free Air Resonance (Fs): 630 Hz
 Sensitivity: 91.0 dB @ 1W/1m
 94.0 dB @ 2.83V/1m
 Electrical "Q" (Qes): 1.009
 Mechanical "Q" (Qms): 2.60
 Total Speaker "Q" (Qts): 0.75

DESIGN BANDWIDTH

With 48 dB/oct. HP filters: 600 Hz - 5 KHz
 With 24 dB/oct. HP filters: 700 Hz - 5 KHz
 With 12 dB/oct. HP filters: 800 Hz - 5 KHz

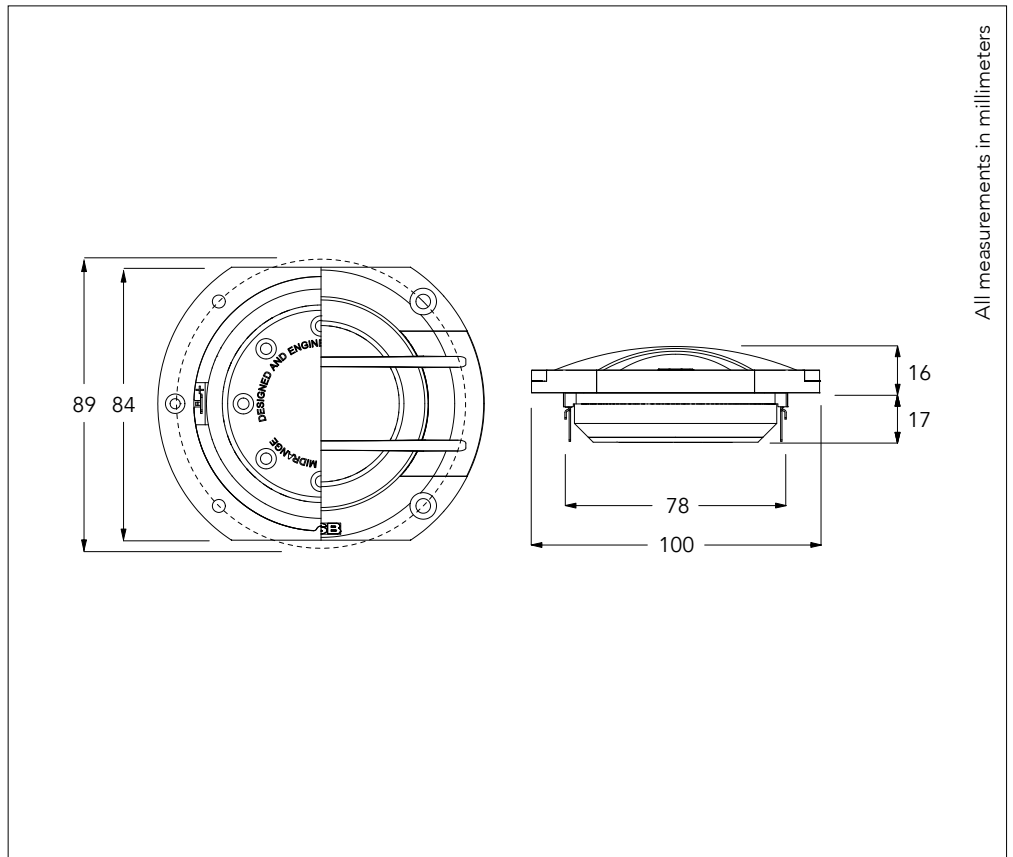

All measurements in millimeters

