

1 Tweeter back cover with ventilations gaps.

2 Damping material, this control the air flow and creates aperiodic resistance. This contributes to a more precise and faithful response to the audio source and to the accuracy and overall quality of the audio experience.

3 Pole cup has twelve axial holes in the bottom made to eliminate the air back pressure caused by the movement of the dome, this solution helps to reduce the distortion that would inevitably be generated due to the deformation of the delicate silk dome, and also helps to reduce the tweeter frequency resonance..

4 N52H neodymium magnet. This high-temperature resistant neodymium magnet is one of the most powerful magnetic structures used on a 25 mm tweeter. The special design of this magnetic assembly ensures that the lines of force are focused right where needed, without any leakage.

5 Magnet plate in ultra-low-carbon steel.

6 ABS main body.

7 Felt damper for controlling and reducing dome resonance.

8 Wide 25 mm lightweight aluminum voice coil with aluminum copper clad winding contributes significantly to the large bandwidth extension of this tweeter.

9 Silk dome impregnated with resin with integrated suspension. This dome is made in a single piece that also includes the suspension, this greatly reduces weight allowing the tweeter to reach very high frequencies, and the absence of joints prevents break-up and/or vibration phenomena.

10 Black kraft paper gasket for eliminate coupling vibrations.

11 CNC-machined billet aluminum flange allows the midrange and tweeter to be mounted using screws, so the two speakers can also be replaced.

12 Light stainless still grill for dome protection.

13 The faceplate haven't only a cosmetic function, but, working as an acoustic lens, its shape dramatically reduces side refractions, which is very unpleasant in a car installation where windows create harmful refractions.

14 Finishing stainless steel ring.

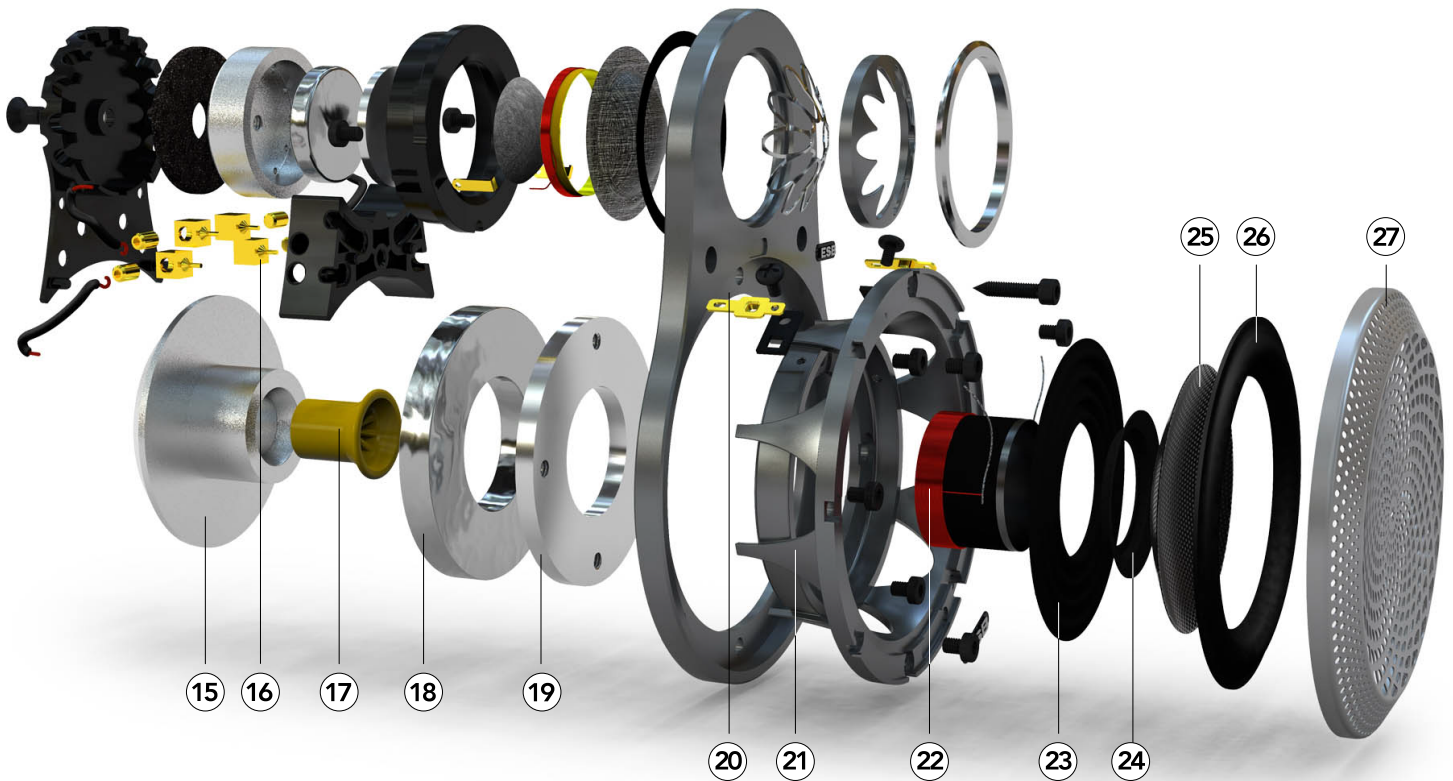

15 Magnet pole yoke designed with the help of magnetic flux analysis software. helped to achieve perfect and homogeneous saturation of the magnetic gap for the benefit of a coil stroke and reduction of distortion and increases dynamics.

16 Integrated terminal connector located between midrange and tweeter, made of pure gold-plated copper, accepts generously sized cables, and their attachment is secured by Allen screws.

17 TCA to control the flow of air moved by the cone creates aperiodic damping resistance and implies that the release of energy accumulated in the movement of the speaker occurs in a controlled and fast manner, without creating persistent oscillations. This contributes to a more precise and faithful response to the audio source and to the accuracy and overall quality of experience.

18 Large neodymium magnet. This neodymium high-temperature resistant magnet is one of the powerful motor magnet structure for a this size car audio midrange driver. This is made from a high grade neodymium and allows the size and bulk of the magnetic motor to be greatly reduced.

19 Pole plate CNC machined from a solid piece of ultra-low-carbon steel.

20 Gold-plated soldering terminal help to save space and prevent any loss of the precious power generated by the amplifier.

21 Die cast-aluminum and powder-coated basket offers very low resistance to the passage of air, and its shape (verified by FEM analysis) reduces vibration and resonance.

22 Wide, lightweight Nomex voice coil with aluminum winding contributes significantly to the wide bandwidth extension.

23 Large balanced Conex™ spider damper device ensures linear excursion in both directions thereby reducing distortion.

24 Collar for joint voice coil and cone, this distribute in a large area the pressure on cone for reduce deformation and distortion.

25 Cone is made with vacuum and autoclave molded high-modulus carbon, a technology rarely used in loudspeakers because of its cost, but it brings enormous benefits in terms of naturalness of reproduction and high dynamics at transients. This is made in a single piece without dust cup, offering incredible advantages in dispersion and regularity of frequency response at the high end.

26 The NBL rubber edge has a shape designed to ensure very smooth movement at very low excursion, becoming increasingly controlled as the excursion increases and approaches the limit. This, too, helps to make this speaker extremely dynamic and capable of handling large powers.

27 CNC-machined aluminum grille.

9.UMA - TWEETER

Speaker Type: Component Tweeter
 Nominal Diameter: 1"/25 mm
 Nominal Impedance (Znom): 4 Ohms
 Continuous Power Handling: 100 W
 Peak Power Handling: 200 W
 Rec. Amplifier Power: 40 - 150W (RMS)

PARAMETERS

Voice Coil Resistance (Re): 3.8 Ohms
 Free Air Resonance (Fs): 1.25 KHz
 Sensitivity: 88.5 dB @ 1W/1m
 91.5 dB @ 2.83V/1m
 Electrical "Q" (Qes): 3.053
 Mechanical "Q" (Qms): 1.874
 Total Speaker "Q" (Qts): 1.116

DESIGN BANDWIDTH

With 48 dB/oct. HP filters: 1.6 KHz - 25 KHz
 With 24 dB/oct. HP filters: 1.9 KHz - 25 KHz
 With 12 dB/oct. HP filters: 2.2 KHz - 25 KHz

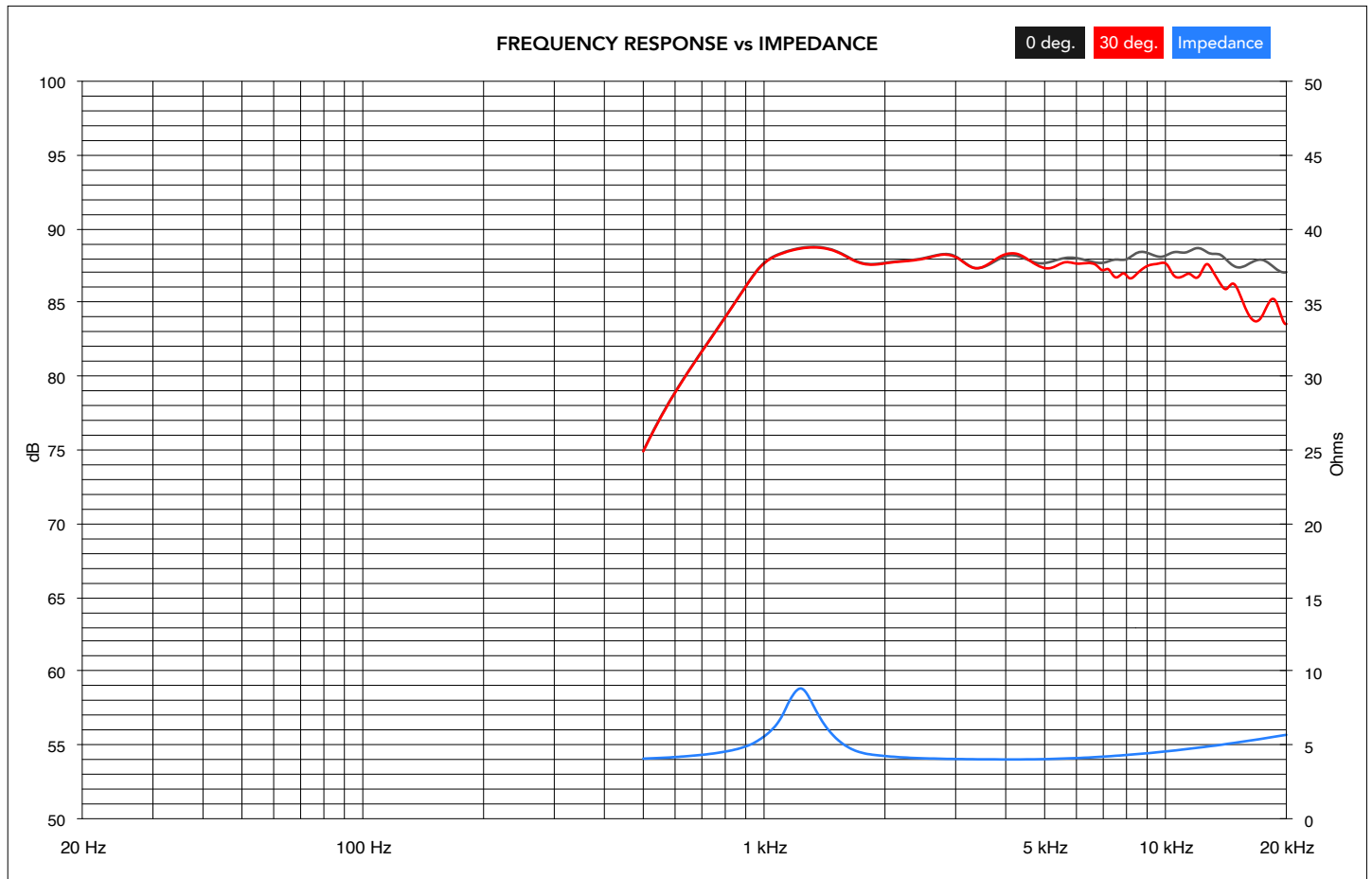
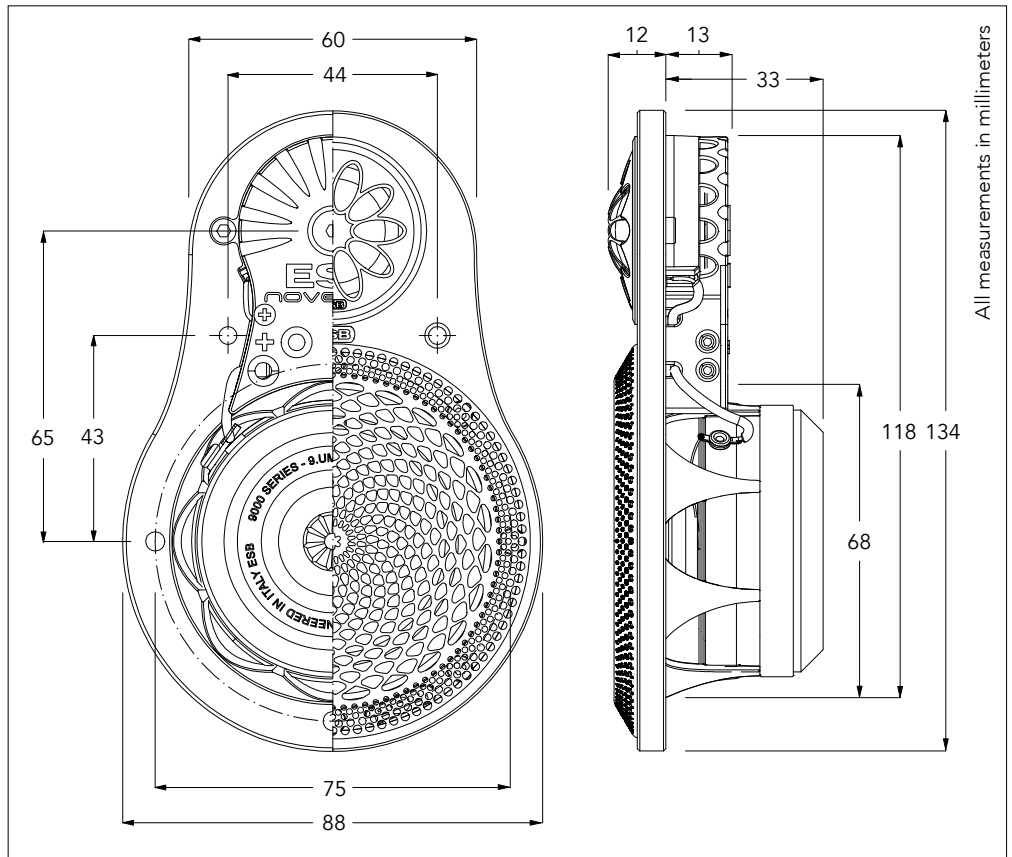

9.UMA - MIDRANGE

Speaker Type: Component Midrange
 Nominal Diameter: 3"/75 mm
 Nominal Impedance (Znom): 4 Ohms
 Continuous Power Handling: 100 W
 Peak Power Handling: 220 W
 Rec. Amplifier Power: 40 - 150W (RMS)
 Driver Rear Displacement: 0.12 lt
 Min. Rec. Sealed Enclosure: 0.6 lt

PARAMETERS

Voice Coil Resistance (Re): 3.6 Ohms
 Voice Coil Diameter: 25 mm
 Free Air Resonance (Fs): 125 Hz
 Reference Efficiency (no): 0.422 %
 Sensitivity: 88.5 dB @ 1W/1m
 91.5 dB @ 2.83V/1m
 Electrical "Q" (Qes): 0.355
 Mechanical "Q" (Qms): 11.364
 Total Speaker "Q" (Qts): 0.344
 Equivalent Compliance (Vas): 0.7 lt
 Moving Mass (Mms): 2.8 g
 Mech. Compliance (Cms): 0.540 mm/N
 Magnetic Strength (BL): 4.841 N/A
 Effective Piston Area (Sd): 31.1 sq. cm
 One-Way Linear Excursion (Xmax): 2.8 mm

DESIGN BANDWIDTH

With 48 dB/oct. HP filters: 100 Hz - 20 KHz
 With 24 dB/oct. HP filters: 120 Hz - 20 KHz
 With 12 dB/oct. HP filters: 140 Hz - 20 KHz

