

1 Magnet pole yoke designed with the help of magnetic flux analysis software. helped to achieve perfect and homogeneous saturation of the magnetic gap for the benefit of a coil stroke and reduction of distortion and increases dynamics.

2 Large neodymium magnet. This neodymium high-temperature resistant magnet is one of the powerful motor magnet structure for a this size car audio midrange driver. This is made from a high grade neodymium and allows the size and bulk of the magnetic motor to be greatly reduced.

3 TCA to control the flow of air moved by the cone creates aperiodic damping resistance and implies that the release of energy accumulated in the movement of the speaker occurs in a controlled and fast manner, without creating persistent oscillations. This contributes to a more precise and faithful response to the audio source and to the accuracy and overall quality of experience.

4 Pole plate CNC machined from a solid piece of ultra-low-carbon steel.

5 Gold-plated soldering terminal help to save space and prevent any loss of the precious power generated by the amplifier.

6 Die cast-aluminum and powder-coated basket offers very low resistance to the passage of air, and its shape (verified by FEM analysis) reduces vibration and resonance.

7 Wide, lightweight Nomex voice coil with aluminum winding contributes significantly to the wide bandwidth extension.

8 Large balanced Conex™ spider damper device ensures linear excursion in both directions thereby reducing distortion.

9 Collar for joint voice coil and cone, this distribute in a large area the pressure on cone for reduce deformation and distortion.

10 Cone is made with vacuum and autoclave molded high-modulus carbon, a technology rarely used in loudspeakers because of its cost, but it brings enormous benefits in terms of naturalness of reproduction and high dynamics at transients. This is made in a single piece by eliminating the dust cup, on a component of this small size, this solution offers incredible advantages in homogeneity of dispersion and regularity of frequency response at the high end.

11 The NBL rubber edge has a shape designed to ensure very smooth movement at very low excursion, becoming increasingly controlled as the excursion increases and approaches the limit. This, too, helps to make this speaker extremely dynamic and capable of handling large powers.

Speaker Type: Component Midrange
 Nominal Diameter: 3"/75 mm
 Nominal Impedance (Znom): 4 Ohms
 Continuous Power Handling: 100 W
 Peak Power Handling: 220 W
 Rec. Amplifier Power: 40 - 150W (RMS)
 Driver Rear Displacement: 0.12 lt
 Min. Rec. Sealed Enclosure: 0.6 lt

PARAMETERS

Voice Coil Resistance (Re): 3.6 Ohms
 Voice Coil Diameter: 25.5 mm
 Free Air Resonance (Fs): 125 Hz
 Reference Efficiency (no): 0.422 %
 Sensitivity: 88.5 dB @ 1W/1m
 91.5 dB @ 2.83V/1m
 Electrical "Q" (Qes): 0.355
 Mechanical "Q" (Qms): 11.364
 Total Speaker "Q" (Qts): 0.344
 Equivalent Compliance (Vas): 0.7 lt
 Moving Mass (Mms): 2.8 g
 Mech. Compliance (Cms): 0.540 mm/N
 Magnetic Strength (BL): 4.841 N/A
 Effective Piston Area (Sd): 31.1 sq. cm
 One-Way Linear Excursion (Xmax): 2.8 mm

DESIGN BANDWIDTH

With 48 dB/oct. HP filters: 100 Hz - 20 KHz
 With 24 dB/oct. HP filters: 120 Hz - 20 KHz
 With 12 dB/oct. HP filters: 140 Hz - 20 KHz

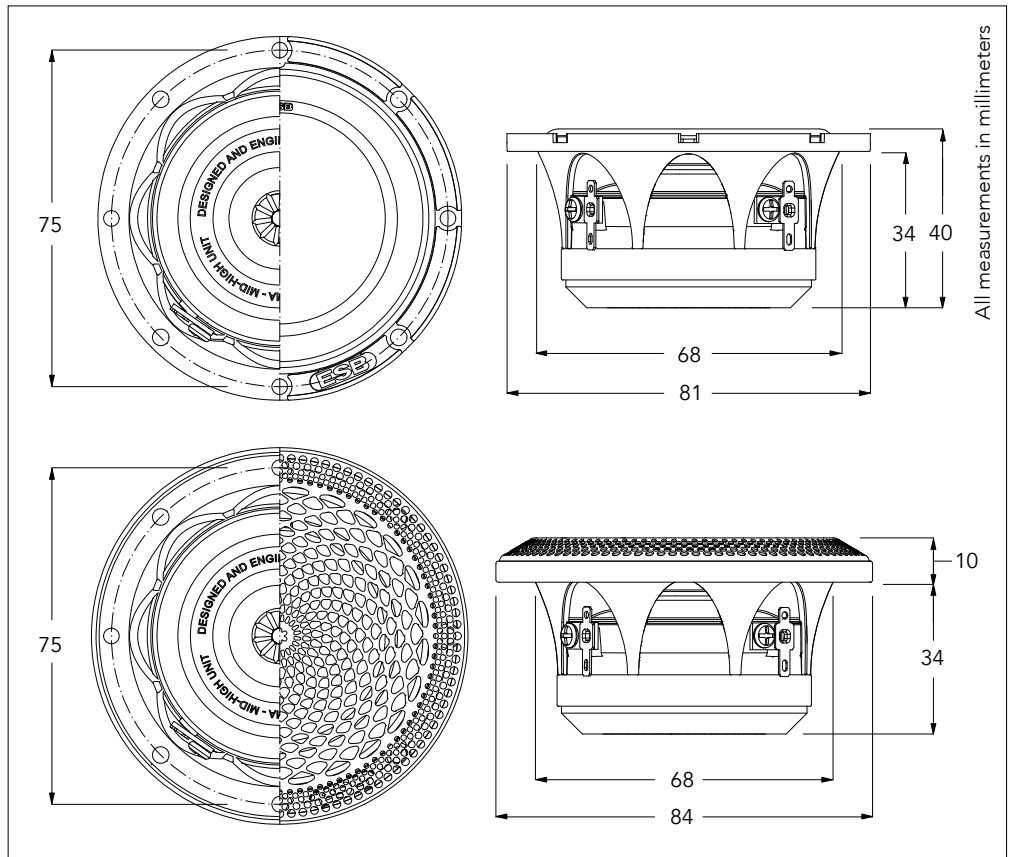

All measurements in millimeters

